

MOUNTING ADJUSTABLE ERGO LEGS TO TABLE TOPS

HARDWARE REQUIRED:



12 tap bolts  
3/4" long



16 washers



4 hex nuts



4 rectangular  
nuts

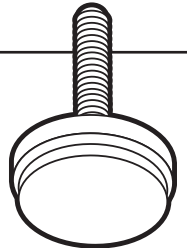

4 leg leveling  
glides

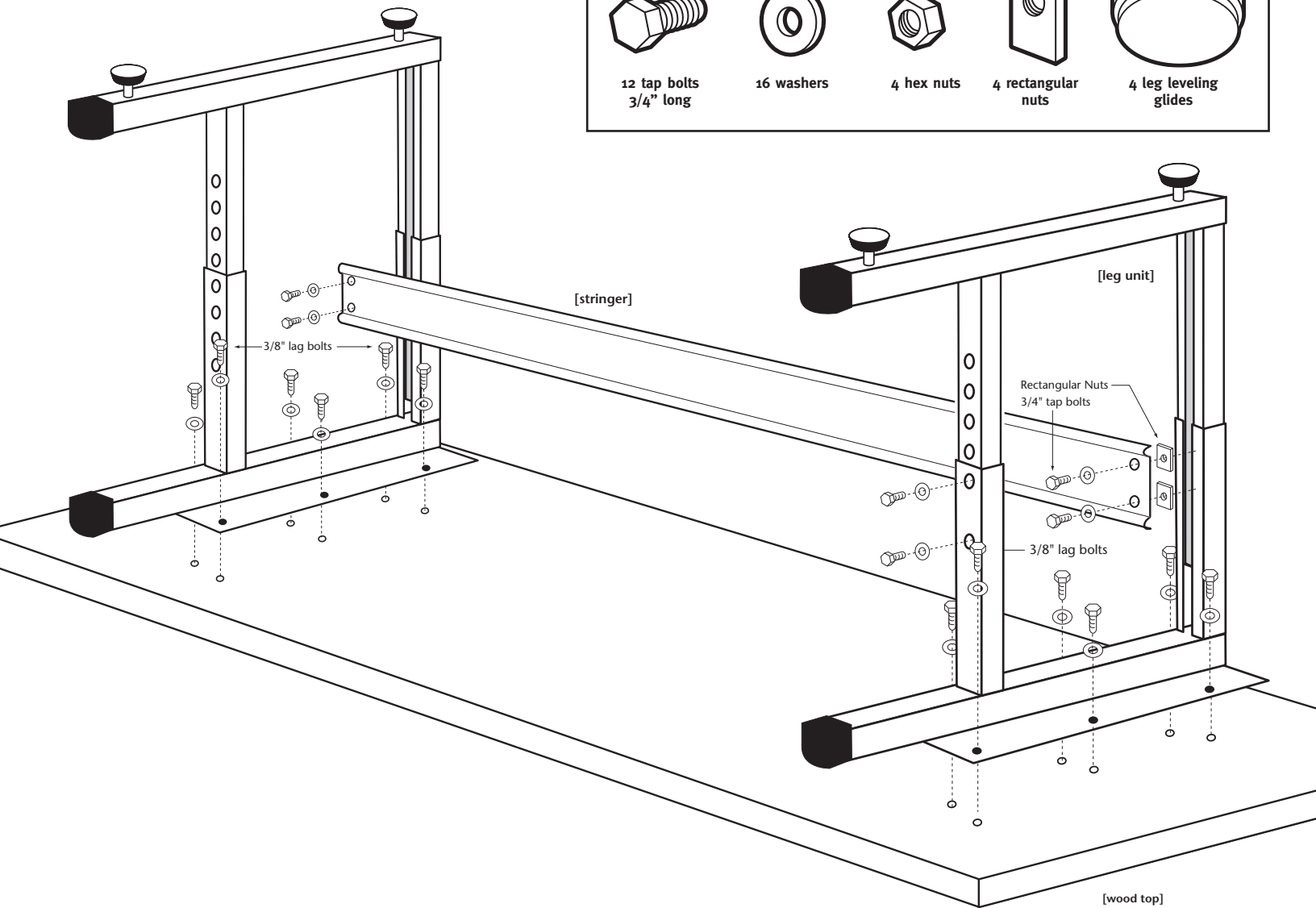

## MOUNTING 2011 ADJUSTABLE LEGS TO WOOD TOP.

Begin the assembly by placing the workbench top with the top surface facing down. Set the legs on top of the wood top with the mounting plates facing down. Attach the stringer loosely to the legs by putting the the tap bolts and one washer per through the provided holes in stringer then thread the rectangular nuts onto the bolts just enough to catch a few threads. Bringing the stringer up to the leg slot with the rectangle nut vertical, slightly angle the assembly so that one side of the nut can slide into the channel and you should be able to get the full nut into the slot. Lightly tighten the stringer to the leg. Center the leg structure side to side on the wood top with the back of the legs flush to the back of the bench top. The next step is to drill pilot holes for attaching the legs to the top. Using a drill with a 9/32" wood bit, drill your pilot holes about 3/4" deep in all 12 mounting points. Now you are ready to insert your lag bolts with a 9/16" socket wrench. Tighten all lag bolts. Finally, tighten the stringer being sure that the rectangular nuts are turned clockwise as far as possible. Now you can flip your bench over and get to work!